

Safety Instructions & Operators Manual

COUNTRY **CLIPPER**[®]

Zero Turn Radius Mower

WRANGLER

SR-125

Congratulations for buying a **Country Clipper** product. Your **Country Clipper** Zero Turning Radius Riding Mower was designed and built to provide long and trouble free service. Keep in mind that it, like any other mechanical device, can be potentially dangerous if used improperly, and hazard control and accident prevention are dependent upon the awareness, concern, prudence, and proper training of personnel involved in the operation, transport, maintenance, and storage of the equipment. Study this manual and pay special attention to the important Safety Precautions on pages 3-5. Following these instructions will help you continue to enjoy the trouble-free performance expected of the **Country Clipper** product.

TABLE OF CONTENTS

<i>SAFETY</i>	3
ACCIDENT PATTERNS TO AVOID	3
SAFETY INSTRUCTIONS AND RECOMMENDATIONS	3
SAFETY INTERLOCK SYSTEM	5
<i>START UP AND OPERATION</i>	6
CHECKLIST BEFORE OPERATION	6
CONTROL LOCATIONS	6
OPERATION	7
MOWING RECOMMENDATIONS	8
<i>MAINTENANCE</i>	9
MAINTENANCE SCHEDULE	9
MAINTENANCE INSTRUCTIONS	10
LEVELING THE DECK	14
PROCEDURE FOR RAISING AND LOWERING THE DECK FOR SERVICING	15
<i>TROUBLE SHOOTING CHECK LIST</i>	17
<i>BELT ROUTINGS</i>	19
<i>WIRING SCHEMATIC</i>	20
<i>NOTES / SERVICE RECORDS:</i>	21

SAFETY

ACCIDENT PATTERNS TO AVOID

- I. **CONTACT WITH THE ROTATING BLADE** -- This accident usually happens when the operator is clearing the discharge chute of grass, (especially when the grass is wet), or when the operator adjusts the machine without turning it off and waiting for the blades to completely stop.
- II. **PROPELLED OBJECTS** -- Sticks, rocks, wires, and other objects can be propelled out through the discharge chute or from under the mower housing. Bystanders are particularly vulnerable.
- III. **GRASS CATCHER OR GUARD** -- The mower shall not be operated without either the entire grass catcher or guard in place.
- IV. **OVERTURNING** -- This happens when riding mowers are used on steep slopes, embankments or hills. The operator in these cases can come in contact with the blades or sustain injuries during a fall.
- V. **MOWER RUNNING OVER THE VICTIM** -- This usually happens when a riding mower is driven in reverse. The accident victims are most often young children whom, unseen by the operator of the mower, were in the area being mowed.

AT **COUNTRY CLIPPER**, WE SHARE YOUR DESIRE TO PROTECT YOURSELF, YOUR FAMILY, YOUR FRIENDS AND YOUR NEIGHBORS FROM ACCIDENTAL INJURY. OBSERVING AND ENFORCING THE FOLLOWING GUIDELINES WILL HELP TO INSURE THE SAFETY OF EVERYONE.

PLEASE BE CAREFUL!

SAFETY INSTRUCTIONS AND RECOMMENDATIONS

1. **PEOPLE WHO OPERATE, SERVICE, OR ARE OTHERWISE ASSOCIATED** with the **Country Clipper** Zero Turning Radius Mower should be trained in its proper use and warned of its dangers. Before operating, adjusting, or servicing the **Country Clipper** Zero Turning Radius Mower they should read and understand this entire manual and the engine owner's manual.
2. **AVOID CONTACT WITH MOVING PARTS.** Keep hands and feet from under mowing deck and away from blades at all times. Turn engine (motor) off if you must unclog the chute.
3. **AVOID HILLS AND SLOPES.** Use extreme caution when mowing up or down slopes. NEVER mow across the face of a slope. If a slope must be ascended, back up the slope; drive forward when descending. Reduce speed and use caution to start, stop and maneuver. To prevent loss of control on a slope avoid sharp turns, sudden changes in direction, and sudden stops and starts.
4. **DISENGAGE POWER TO MOWER BEFORE BACKING UP.** Do not mow in reverse unless ABSOLUTELY necessary and then only after turning around and observing the entire area behind the mower. Go slowly. Most "running over victim" accidents occur in reverse.
5. **BEGINNING OPERATORS SHOULD LEARN HOW TO STEER** the **Country Clipper** Zero Turning Radius Mower before attempting to mow. Start with slow engine speed and drive without the blades engaged in an open area until comfortable with the machine.
6. **KNOW HOW TO STOP QUICKLY.** Know the location and operation of every control, especially how to brake and how to disengage the mower blades.

7. **DO NOT MOVE CONTROL LEVER(S)** from forward position to reverse position rapidly. The speed and/or direction of travel is affected instantly by movement of the Control Lever(s).
8. **DO NOT ALLOW CHILDREN TO OPERATE MOWER.** Do not allow others who have not had instruction to operate mower.
9. **ALWAYS TURN ENGINE OFF AND REMOVE KEY** before leaving the mower to prevent children and inexperienced operators from starting the engine. Never leave the mower unattended with engine running. Always wait for all moving parts and all sounds to stop before leaving operator's seat.
10. **WEAR STURDY, ROUGH-SOLED WORK SHOES AND CLOSE-FITTING SLACKS AND SHIRTS.** Never operate mower in bare feet, sandals or sneakers.
11. **KNOW THE AREA YOU ARE TO MOW.** Watch for hidden danger such as rocks, roots, sticks, holes, bumps, and drop-offs, etc. Before mowing, pick up all debris in area to be mowed. Sharp and hard objects can be propelled at a high speed and can act like shrapnel. Walk through tall grass **BEFORE MOWING** to make sure there are no hidden dangers. Mow higher than desired in tall grass to expose any hidden objects and/or obstacles, clean the area, and then mow to the desired height.
12. **NEVER REFUEL A MOWER INDOORS.** Allow the engine time to cool before refueling. Unseen vapors may be ignited by a spark. Always clean up spilled gasoline. Never run the engine indoors in a garage or any other closed building. Allow engine to cool before storing in any enclosure. The engine exhaust and gasoline fumes are dangerous.
13. **DISENGAGE BLADES BEFORE DRIVING ACROSS WALKS** or projecting objects.
14. **NEVER REMOVE THE FUEL CAP** or add gasoline to a running or hot engine that has not been allowed to cool for several minutes after running. Always make sure the gas cap is in place.
15. **NEVER CARRY PASSENGERS.**
16. **DO NOT SMOKE AROUND THE MOWER** or the gasoline storage container. Gasoline fumes can easily ignite.
17. **KEEP GASOLINE IN A WELL-VENTILATED AREA** away from your living quarters and in tightly-capped safety cans. Never store mower with gasoline in the tank inside a building where fumes may reach open flame or spark.
18. **DISENGAGE BLADES, STOP ENGINE AND REMOVE IGNITION KEY** before any servicing. Be sure all moving parts and all sounds have stopped. Let engine cool and disconnect the spark plugs so the engine cannot start by accident. A SLIGHT ROTATION OF THE BLADES COULD START THE ENGINE.
19. **KEEP ALL NUTS, BOLTS, AND SCREWS TIGHT** to be sure equipment is in safe working condition, especially blade mounting bolts.
20. **VEHICLE SHOULD BE STOPPED AND INSPECTED FOR DAMAGE** after striking a foreign object and the damage should be repaired before restarting and operating the equipment. Stop immediately and check for damage or loose parts if mower should start vibrating.
21. **KEEP SAFETY DEVICES AND GUARDS IN PLACE.** If any of the safety switches become inoperable, have them repaired immediately.
22. **DO NOT STEP OR STAND ON THE MOWER HOUSING.** Step or stand only on the foot deck.
23. **WATCH OUT FOR TRAFFIC** near roadways and when crossing roads.
24. **DO NOT USE MOWER WHEN GRASS IS WET OR SLIPPERY.**
25. **MOW ONLY DURING DAYLIGHT.**

26. **THIS MACHINE IS NOT MEANT FOR HIGHWAY OR STREET USE.** It is not a recreational vehicle and it should not be operated as such.
27. **ALWAYS DISENGAGE THE MOWER BLADE CLUTCH** when transporting.
28. **KEEP ALL SAFETY LABELS IN LEGIBLE CONDITION.** Remove grease, dirt, grass, etc. that may cover safety labels. Replace any safety label that is missing or damaged.
29. **WEAR PERSONAL PROTECTIVE EQUIPMENT.** Eye, ear, feet and head protection is recommended.
30. **ONLY USE COUNTRY CLIPPER APPROVED ACCESSORIES.**
31. **DO NOT CHANGE THE ENGINE GOVERNOR SETTING** or over speed the engine.
32. **BEWARE OF MOWER DISCHARGE DIRECTION** and do not point it at anyone.
33. **DO NOT OPERATE THE MOWER UNDER THE INFLUENCE OF ALCOHOL OR DRUGS.**
34. **USE CARE WHEN LOADING OR UNLOADING MACHINE INTO A TRAILER OR TRUCK.**
35. **USE CARE WHEN APPROACHING BLIND CORNERS,** shrubs, trees, or other objects that may obscure vision.
36. **CLEAN ALL GRASS AND DEBRIS FROM MACHINE TO PREVENT FIRES.** Remove spilled oil or gasoline.
37. **KEEP HANDS AND FEET AWAY FROM MOVING PARTS.** If possible do not make adjustments with the engine running.
38. **NEVER MOW WHEN OTHER PEOPLE OR PETS ARE IN THE AREA.**
39. **CAREFULLY RELEASE PRESSURE FROM COMPONENTS WITH STORED ENERGY.**
40. **USE CARE WHEN REPLACING BLADES.** Wrap the blade(s) or wear gloves, and use caution when servicing

them. Only replace blade(s). Never straighten or weld blade(s).

41. **USE JACKSTANDS TO SUPPORT COMPONENTS** when required.

SAFETY INTERLOCK SYSTEM

Your *Country Clipper* Zero Turning Radius Mower is equipped with switches interlocked for your safety.

GROUND DRIVE NEUTRAL IS WHEN THE JOYSTICK CONTROL LEVER IS IN THE “DOWN” POSITION.

1. The mower blades must be disengaged before engine will start.
2. The Joystick Control Lever must be in the neutral position before the engine will start.
3. The engine will stop if the mower blade clutch is engaged when the operator leaves the driver’s seat.
4. The engine will stop if the Joystick Control Lever is not in the neutral position when the operator leaves the driver’s seat.
5. The engine will stop if the brake is “SET” and the Joystick Control Lever is not in the neutral position.
6. The engine will stop if the brake is “SET” and the mower blade clutch is engaged.

DO NOT OPERATE MOWER IF SAFETY SWITCHES AND GUARDS ARE NOT OPERATING PROPERLY

START UP AND OPERATION

CHECKLIST BEFORE OPERATION

1. Make sure fuel tank is full. Use regular unleaded gasoline (see engine owner's manual for more details).



WARNING



HANDLE GASOLINE WITH CARE -- IT IS HIGHLY FLAMMABLE. DO NOT SMOKE. ENGINE SHOULD BE OFF AND COOL. USE APPROVED GAS CONTAINER. NEVER FILL TANK INDOORS. WIPE UP ANY SPILLS. REPLACE CAP TIGHTLY.

2. Make sure dirt and foreign matter is kept out of gas tank. Use a clean funnel and gas can.
3. Do not mix oil with gasoline.
4. Do not use white, high test or premium gasoline. Do not use de-icers, carburetor cleaners, or other such additives.
5. Check the crankcase oil level. Make sure the engine is off. The mower should be parked on a level area. Do not overfill. (See your engine manual for more detailed instruction.)
6. Check battery fluid level.
7. Inspect V-belts.
8. Check tire pressure.
9. Make sure underside of mower deck is free of grass.
10. Make sure mower blades are sharp and secured tightly.
11. Clean the air intake screen on the engine if necessary.
12. Perform any other maintenance as it becomes necessary. (See the "Maintenance" section of this manual.)

IMPORTANT: Before cutting grass, clutch must be broken-in as follows: With engine at full RPM engage deck until blades come to full speed and then disengage until blades come to a complete stop. Repeat 10 times to "break-in" the clutch properly.

CONTROL LOCATIONS

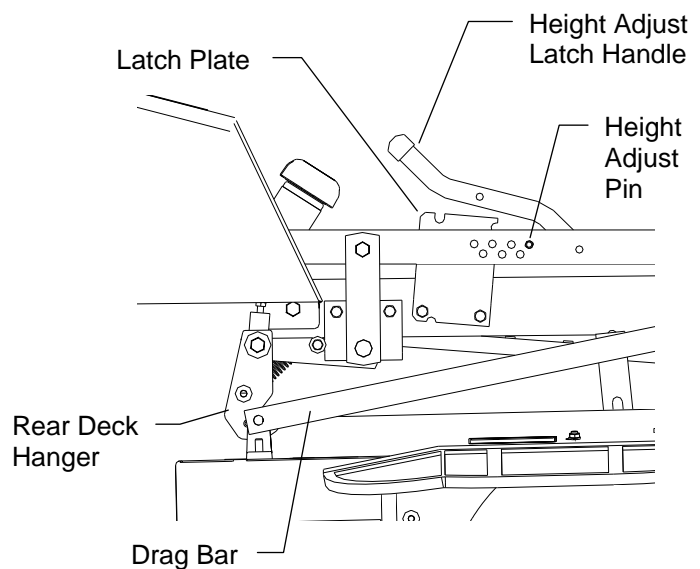
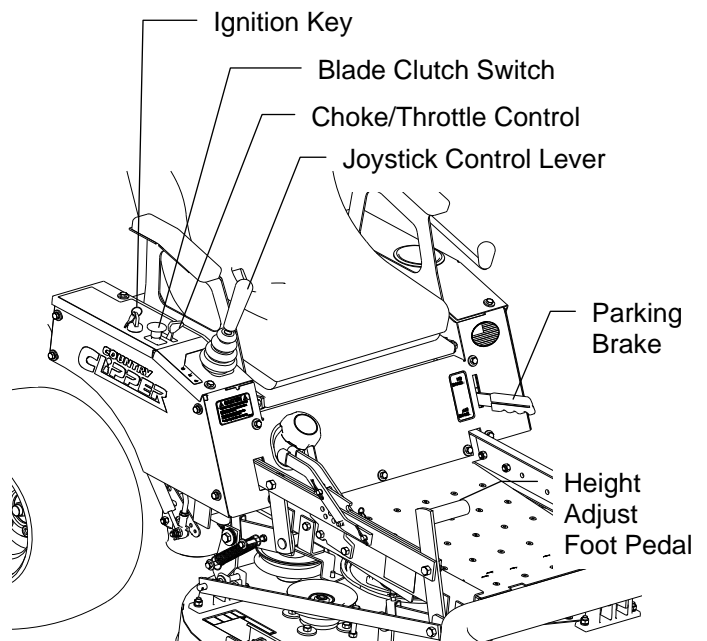



WARNING



AVOID INHALING EXHAUST FUMES -- CARBON MONOXIDE GAS IS COLORLESS AND ODORLESS, AND CAN CAUSE UNCONSCIOUSNESS, AND IS POTENTIALLY LETHAL. DO NOT RUN LAWN MOWER IN GARAGE OR OTHER CONFINED AREA.

OPERATION

1. MOVE JOYSTICK CONTROL LEVER to neutral "DOWN" position.
2. SET PARKING BRAKE. Pull up to set.
3. DISENGAGE MOWER BLADE CLUTCH by moving clutch switch to "OFF" position.
4. PUSH ENGINE CHOKE/THROTTLE CONTROL to full position for cold starts.
5. TURN IGNITION KEY to "START" position and release to "RUN" as soon as engine starts. NOTE: Prolonged cranking will damage starter motor and shorten the battery life
6. ADJUST ENGINE CHOKE/THROTTLE CONTROL for desired engine smoothness and speed. NOTE: When mowing, always run engine at full throttle.
7. RELEASE PARKING BRAKE. Push brake lever down to release.

IMPORTANT: Until the operator is familiar with the *Country Clipper* Zero Turning Radius Mower, he/she should follow these recommendations: Disengage the mower blades. Go very slowly until thoroughly familiar with the machine. Keep away from fences, buildings, and other obstructions. Move the Joystick Control Lever smoothly and slowly. Practice until operation is smooth and efficient.

8. TO DRIVE: Move the Joystick Control Lever to the "UP" position.
 - A. Move the Joystick Control Lever forward to move forward. Increasing forward movement of the Joystick Control Lever will increase the speed of travel.

- B. To reverse the direction, pull the Joystick Control Lever slightly back.
- C. To turn, move the Joystick Control Lever toward the direction you want to turn.
- D. To turn on a zero radius axis, go slowly and move the Joystick Control Lever to the side you wish to turn and slightly to the rear at the same time.



CAUTION



FOR SMOOTH, SAFE OPERATION, MOVE THE JOYSTICK CONTROL LEVER IN A GENTLE, SLOW MOTION. NEVER PULL OR PUSH THE JOYSTICK CONTROL LEVER RAPIDLY, ESPECIALLY ON GRADES.

9. BRAKING: To brake mower, gently move the Joystick Control Lever in the direction opposite to travel. If the parking brake is engaged with the Joystick Control Lever in the "UP" position the engine will stop.
10. CUTTING HEIGHT ADJUSTMENT: Push the Height Adjustment Foot Pedal forward until Height Adjustment Latch Handle engages the Latch Plate. Move the Height Adjustment Pin to the desired cutting height hole. Push and hold the Height Adjustment Foot Pedal forward while raising the Height Adjustment Latch Handle to disengage from the Latch Plate. Slowly lower the Height Adjustment Foot Pedal until the Height Adjustment Pin contacts the Latch Plate.
11. ENGAGE MOWER BLADE CLUTCH: Set the Blade Clutch Switch to the "ON" position. The engine will not start if the blade clutch is engaged. If the operator is not in the seat, the engine will stop if the clutch is engaged



CAUTION



AVOID HILL AND SLOPES. USE EXTREME CAUTION WHEN MOWING UP OR DOWN SLOPES. NEVER MOW ACROSS THE FACE OF A SLOPE. IF A SLOPE MUST BE ASCENDED, BACK UP THE SLOPE; DRIVE FORWARD WHEN DESCENDING.

12. TO STOP:

- A. Move Joystick Control Lever to neutral position and then to the "DOWN" position.
- B. Disengage the mower blade clutch by moving the clutch to the "OFF" position.
- C. Set the parking brake.
- D. Slow engine speed with throttle to slowest position.
- E. Turn ignition key to "OFF" position.
- F. Remove the key and wait for all movement and all sound to cease before dismounting.

NOTE: The tractor should never be pulled at more than 2 miles per hour or for any appreciable distance.

! CAUTION !

WHEN LEAVING THE MOWER UNATTENDED, ALWAYS REMOVE THE KEY AND SET THE PARKING BRAKE, EVEN IF JUST FOR A FEW MOMENTS. HELP PROTECT CHILDREN AND OTHER UNAUTHORIZED PERSONS FROM ACCIDENTS.

! CAUTION !

NEVER OPERATE MOWER WITH OUT DISCHARGE CHUTE IN PLACE

MOWING RECOMMENDATIONS

- 1. Keep mower blades sharp.
- 2. Make sure deck and discharge are clean.

! CAUTION !

POWER MUST BE OFF TO CLEAN DISCHARGE CHUTE. TURN ENGINE OFF AND WAIT FOR ALL MOVING PARTS TO STOP.

13. TO FREE WHEEL MACHINE: UNLOCK TRANSMISSION: Pull the Transmission Release Chains out away from the Hydrostatic Transmission and then down into the retaining slot (each side must individually be pulled out and down into the retaining slot). To re-engage the transmissions push the Transmission Release Chains out of the retaining slot.

The Transmission Release Chains are located on the rear side of the Hydrostatic Transmission and below the Engine Mounting Plate.

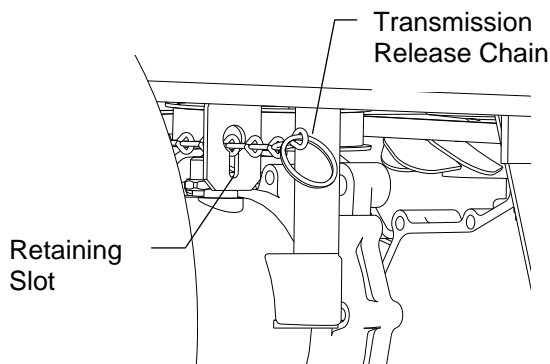

- 3. When mowing tall grass, make two passes, mowing off 1/2 of the desired cut on the first pass, and then the desired height the second pass. Check for hidden dangers first.
- 4. Go slowly for trimming.
- 5. Always cut grass with the engine at full throttle speed. This "ENGINE" speed allows the cutting blades to operate at optimum cutting speed. Control "GROUND" speed with the Joystick Control Lever.
- 6. Vary ground speed to suit conditions (i.e. go slower in tall thick grass, on hills, wet conditions, etc.).

MAINTENANCE



CAUTION



BEFORE PERFORMING ANY MAINTENANCE, TURN OFF ENGINE REMOVE KEY AND DISCONNECT SPARK PLUGS. USE EXTREME CARE WHEN WORKING ON MACHINERY. DO NOT WEAR WATCHES OR JEWELRY. DO NOT WEAR LOOSE FITTING CLOTHES, AND OBSERVE ALL COMMON SAFETY PRACTICES WITH TOOLS.

MAINTENANCE SCHEDULE

SERVICE	WHEN
Check crankcase oil level -----	before each use
Clean grass from Hydrostatic Transmission fins and cooling fans -----	before each use
Check air intake screen -----	after each use
Clean grass under deck -----	after each use
<i>NOTE: Allow deck to cool for minimum of 20 minutes, if using water to clean deck NEVER clean deck with high pressure washer</i>	
Check tire pressure -----	every 10 hours
Check battery fluid -----	every 10 hours
Sharpen mower blades -----	every 10 hours
Clean air filter pre-cleaner element -----	every 25 hours
Grease Front Caster Yoke Spindles -----	every 25 hours
Check drive belts -----	every 50 hours (20 hours break-in)
Change Air Cleaner Filter Element -----	every 100 hours
Change engine crankcase oil and Oil Filter-----	every 100 hours
Check and Re-gap Spark Plugs -----	every 200 hours
Change spark plugs -----	500 hours
Service battery -----	annually or 500 hours

Replace decals when illegible. Write factory for free replacement.



MAINTENANCE INSTRUCTIONS

1. ENGINE:

For complete maintenance and operating information for your engine, please refer to your engine operating and maintenance instructions furnished by the engine manufacturer and included in your **Country Clipper** Zero Turning Radius Mower information packet.

NOTE: Air intake screen must be kept clean. If plugged, engine may be seriously damaged by over heating.

2. BATTERY:

CAUTION

BATTERY ELECTROLYTE IS A POISONOUS AND CORROSIVE SULFURIC ACID SOLUTION. AVOID SPILLING ON SKIN, EYES, AND CLOTHING.

Keep the electrolyte level above the plates in each cell by adding distilled water as it becomes necessary. Add water just before operating the mower to mix the water with the solution. Be careful not to overfill the battery -- the electrolyte solution is corrosive and can cause damage to surrounding metal parts if it should spill. When taking the battery out of the mower for servicing, make sure to connect the cables to the battery exactly as they were prior to removal. Always disconnect the ground (-) wire first and always reconnect the ground (-) wire last.

Keep the battery clean. Remove the corrosion around the battery terminals by applying a solution of one part baking soda to four parts water. Coat all exposed terminal surfaces with a light layer of grease or petroleum jelly to prevent corrosion.

NOTE: At temperatures below 32 degrees F (0 degrees C) the full charge state must be maintained to prevent cell electrolyte from freezing and causing permanent battery damage.

3. TIRES:

Correct tire pressure is essential for efficient operation of the mower. Check tire pressure as requested in the maintenance schedule. Inflate tires to the pressures listed below:

Model	Front tires	Rear tires
All Models	12 psi	12 psi

Lug nuts should be torqued to 75 ft/lbs and checked regularly for tightness.

4. MOWER BLADES:

Check sharpness of mower blades after every 10 hours of operation. To sharpen blades proceed as follows:

CAUTION

STOP ENGINE, REMOVE IGNITION KEY AND SPARK PLUGS FOR SAFETY.

- A. Remove bolt and thrust washer mounting blade on shaft. Remove blade.
- B. Blades should be discarded when worn excessively.

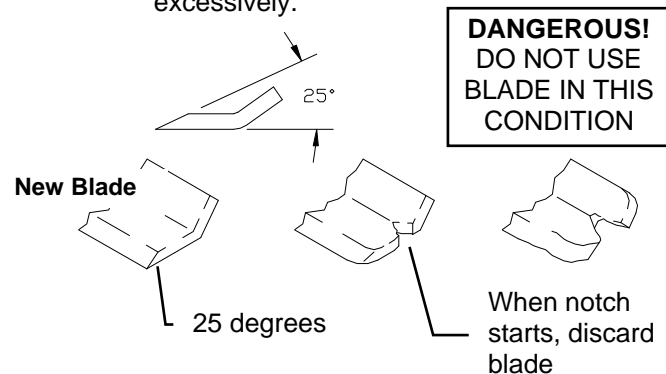

- C. Sharpen blades with a hand file, electric grinder or blade sharpener. Wear gloves and eye protection when sharpening. Grind blade at original 25 degree level.
- D. Check balance of blade by positioning the blade on a nail or blade balance pedestal. Grind the blade on the end that is heavier until both sides balance.
- E. Install blade, thrust washer, and bolt. Make sure to tighten bolt to 100 ft-lbs.

5. V-BELTS:

All belts should be checked every 50 hours. Replace any belts found to be in poor condition. All belts are equipped with spring loaded belt tighteners and do not require tightening adjustments.

6. LUBRICATION:

- A. Engine: Follow engine manufacturer's recommendation.
- B. Caster Yoke Spindles: Lubricate with high quality grease every 25 hours.

7. PARKING BRAKE ADJUSTMENT:

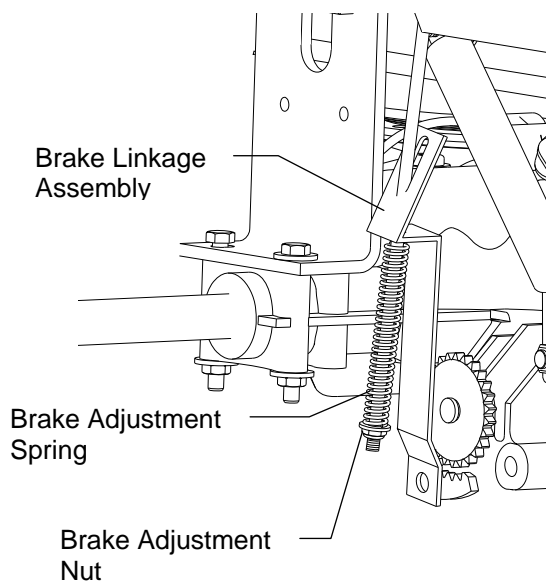

- A. Move Parking Brake Lever to the "OFF" position.
- B. Tighten the Brake Adjustment Nut until the Brake Adjustment Spring just begins to collapse on the Brake Linkage Assembly.
- C. Repeat for the other side

NOTE: With the Brake Lever in the "OFF" position the teeth of the brake disk mechanism should not be engaged.

8. JOYSTICK CONTROL LEVER NEUTRAL ADJUSTMENT:

With the engine running, if the machine travels in either direction when the Joystick Control Lever is in the neutral "DOWN" position, stop the engine, securely elevate the rear wheels clear of the ground and adjust as follows:

TO ADJUST RIGHT HAND SIDE: (see next page for illustration)

- A. Remove the right hand fender skirt exposing the Joystick Control Lever Assembly.
- B. Start and run engine at fast idle with Joystick Control Lever in the "DOWN" position.
- C. Loosen the locknuts tightened against the Upper Rod End Ball Joint and Adjusting Coupler on the Upper Linkage Rod Assembly.

NOTE: One of these is a left hand nut and will have to be turned backwards.

NOTE: Use 2 wrenches (one on the Adjusting Coupler and one on the locknut) when loosening locknuts to prevent damage to Rod End Ball Joints.

- D. Adjust the neutral position by turning the Adjusting Coupler until the wheel stops turning.
- E. Retighten the locknuts and check to make sure the drive wheel is still not turning.

NOTE: Use 2 wrenches (one on the Adjusting Coupler and one on the locknut) when tightening locknuts to prevent damage to Rod End Ball Joints.

- F. Shut off engine before removing from blocks. Replace fender skirt.

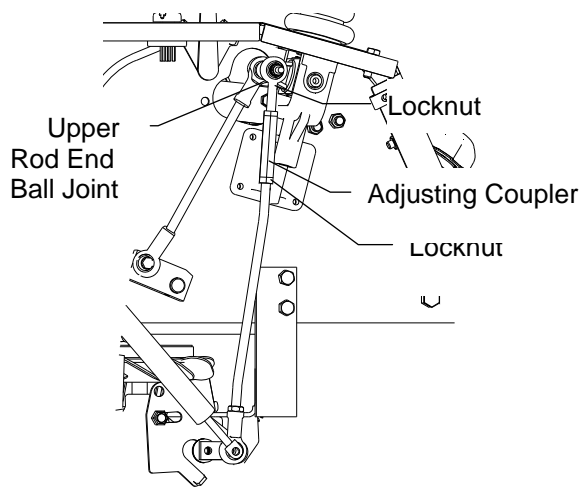

NOTE: Use 2 wrenches (one on the Rod End Ball Joint and one on the locknut) when tightening locknuts to prevent damage to Rod End Ball Joints.

- K. Shut off engine before removing from blocks.

9. JOYSTICK CONTROL LEVER SENSITIVITY ADJUSTMENT

To change the sideways turning response adjust as follows:

- A. Remove the right hand fender skirt exposing the Joystick Control Lever assembly.
- B. Remove the cross bolt, nut, and spacers
- C. Reassemble the spacers as desired. (2) spacers between the rod end ball joints and the joystick pivot shaft will quicken the side to side response, (1) spacer slows the response.

TO ADJUST LEFT HAND SIDE:

- G. Start and run engine at fast idle with Joystick Control Lever in the "DOWN" position.
- H. Loosen locknuts tightened against the Rod End Ball Joints on the Left Hand Lower Linkage Rod Assembly.

NOTE: One of these is a left hand nut and will have to be turned backwards.

NOTE: Use 2 wrenches (one on the Rod End Ball Joint and one on the locknut) when loosening locknuts to prevent damage to Rod End Ball Joints.

- I. Adjust neutral position by turning rod in the Left Hand Lower Linkage Rod Assembly until the wheel stops turning.
- J. Retighten the locknuts and check to make sure the drive wheel is still not turning.

NOTE: It is important that there is at least one spacer on each side of the rod end ball joints to prevent damage. Also the small diameter of the spacer must point towards the rod end ball joint.

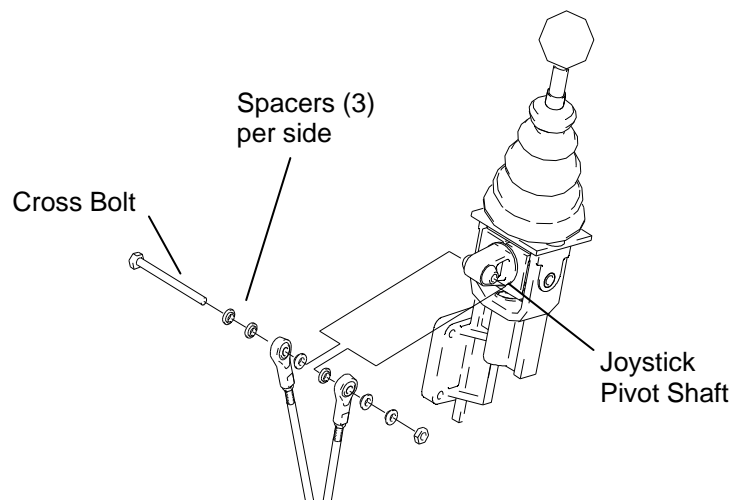
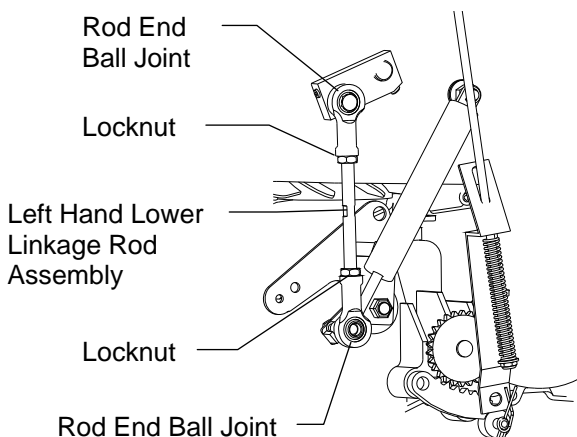

10. JOYSTICK CONTROL LEVER DETENT ADJUSTMENT:

If the Joystick Control Lever does not lock in the "UP" position, turn the detent adjustment screw clockwise until a desirable locking action is obtained. If the Joystick Control Lever is hard to slide up and down, turn the detent adjustment screw counter-clockwise until a desirable sliding action is obtained.

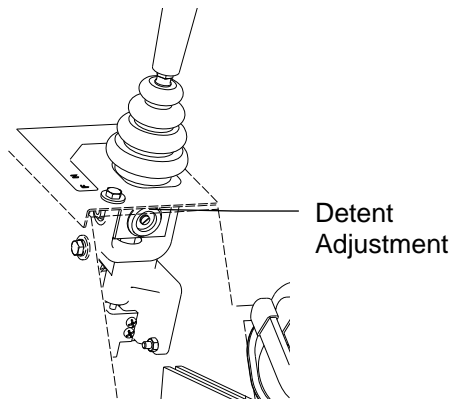

11. ADJUSTING FOR STRAIGHT FORWARD TRACKING:

In a flat open area, actuate the Joystick Control lever into the full forward position. If the mower veers left or right some adjustment is necessary. If the mower veers to the right, the left hand Hydrostatic Transmission needs to be slowed down or the right hand Hydrostatic Transmission needs to be sped up. If the mower veers to the left, then the right hand Hydrostatic Transmission needs to be slowed down or the left hand Hydrostatic Transmission needs to be sped up.

- A. Stop the machine and shut off the engine.
- B. For the Hydrostatic Transmission to be adjusted slightly loosen bolt that secures Cam Adjustment Block to the Control Arm of the Hydrostatic Transmission.
- C. Rotate Cam Adjustment Block "UP" to speed up Hydrostatic Transmission and "DOWN" to slow down Hydrostatic Transmission.
- D. Retighten bolt that secures Cam Adjustment Block.

- E. Readjust neutral according to previously outlined procedures.
- F. Test drive unit and repeat procedure as required.

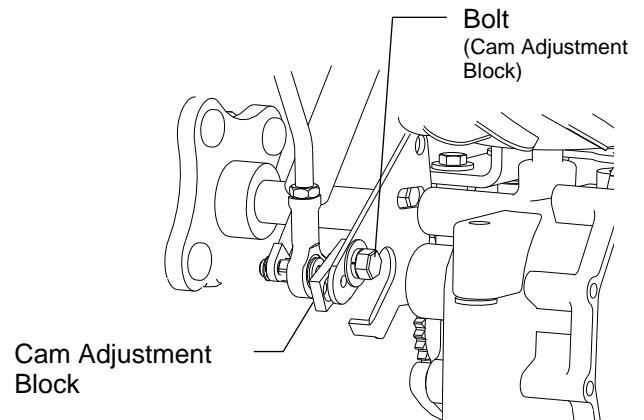

12. HYDROSTATIC TRANSMISSIONS:

Before each use, check to be sure that the cooling fins of the Hydrostatic Transmissions are clean. Excessive accumulation of oil, dirt, or trash may cause the transmissions to overheat.

NOTE: NEVER WASH ACROSS VENT HOSE AREA OR SHAFT SEALS WITH WATER OR STEAM.

LEVELING THE DECK

NOTE: DECK HAS BEEN LEVELED AT THE FACTORY. IF LEVELING IS REQUIRED USE THE FOLLOWING PROCEDURES

1. Move the tractor to a hard surface (i.e. concrete or blacktop). Remove the Ignition Key.
2. Set the tire pressure on each of the four tires to 12 psi
3. Set the deck cutting height to the highest position and rotate both blades by hand until one end of each blade points forward (toward the front of tractor). Take care when rotating blades, the end of the blade can be sharp.
4. Measure from the ground to the front blade tip of each blade. These measurements should be within 1/8" of each other. (NOTE: To simplify this measuring, an optional Blade Measuring tool, part Number 629-374A is available from your local "Country Clipper" Dealer)
5. If adjustment is necessary slightly loosen the locknuts that secure the Deck Hanger mounting bolt. Turn Deck Height Adjustment Bolt to desired setting. Re-tighten locknuts that secure Deck Hanger mounting bolt. NOTE: When tightening locknuts ensure that the Deck Hanger still pivots freely (i.e. clamp forces should be against Deck Height Adjuster not the Deck Hanger).
6. Once the side-to-side cut height is within tolerance, measure from the ground to the blade tip at the rear of each blade. This measurement should be between 1/8" to 1/4" higher from the ground than the front of the blade tip from the ground on the corresponding side of the deck. Adjust the Rear Deck Hangers and/or Front Deck Hangers accordingly to obtain the proper measurements.
7. Double check all measurements and insure that all locknuts are securely fastened without binding on the front or rear Deck hangers

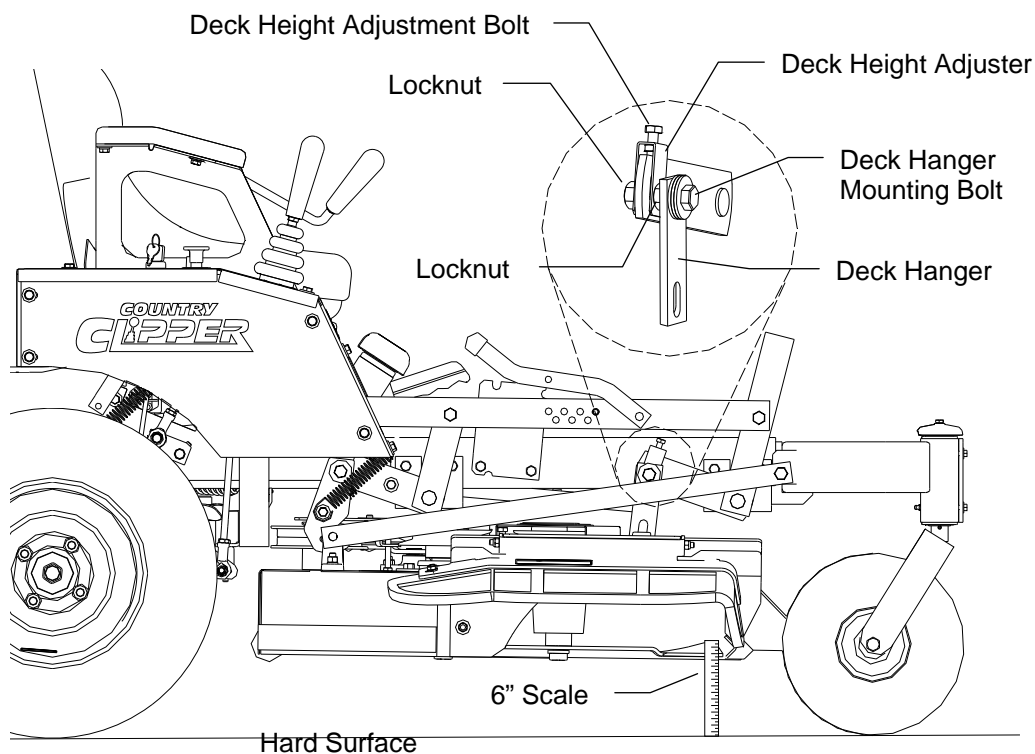

PROCEDURE FOR RAISING AND LOWERING THE DECK FOR SERVICING

(see next page for illustrations)

1. RAISING THE DECK:

- A. Push Height Adjustment Foot Pedal forward until the Height Latch Handle engages Latch Plate. Remove Cut Height Adjustment Pin. Push and hold the Height Adjustment Foot Pedal forward while raising the Height Adjustment Latch Handle to disengage from the Latch Plate. Slowly lower the Height Adjustment Foot Pedal until Deck rests on the ground. Ensure that Height Latch Handle engages retaining slot located in top of Latch Plate.
- B. Carefully rotate the Deck Belt Tension Lever to release tension on the Deck Belt. Remove the engine to deck Drive belt from the clutch on the engine.
- C. Using Deck Drag Bar as a handle, lift rear corner of the Deck and disconnect the Rear Deck Hanger. Rotate Rear Deck Hanger completely "over-center" so it is out of harms way when raising and lowering the deck. Repeat for the opposite side of the deck.
- D. Position the front caster wheels so they are away from the deck (such as the tractor would be traveling in reverse).
- E. Lift the front of the deck until the deck is standing vertically (lifting can be made easier if someone pushes down on the rear end of the tractor).

IMPORTANT NOTE: PRIOR TO LETTING GO OF THE DECK MAKE SURE THAT THE DECK IS LIFTED FAR ENOUGH TO STAND COMPLETELY UPRIGHT BY ITSELF.

This will prevent the deck from falling down when servicing the underside of the mower deck

2. LOWERING THE DECK:

- A. While firmly holding the Deck Lift Handle push the bottom (back) of the deck towards the rear of the tractor. Lower the deck until it rests on the ground.
- B. Using the Deck Drag Bar as a handle, lift the rear corner of the deck and connect the Rear Deck Hanger. Repeat for the opposite side of the deck.
- C. Install the engine to deck belt onto the clutch on the engine.
- D. Ensure that the engine to deck drive belt is installed onto all of the pulleys and idlers in the drive train. Carefully rotate the Deck Belt Tension Latch to re-tension the Deck Belt.
- E. Raise the Height Adjustment Latch Handle up and out of the slot in the top of the latch Plate. Push the Height Adjustment Foot Pedal forward until Height Adjustment Latch Handle engages the Latch Plate. Move the Height Adjustment Pin to the desired cutting height hole. Push and hold the Height Adjustment Foot Pedal forward while raising the Height Adjustment Latch Handle to disengage from the Latch Plate. Slowly lower the Height Adjustment Foot Pedal until the Height Adjustment Pin contacts the Latch Plate.

MOWER SHOWN IN OPERATION POSITION.

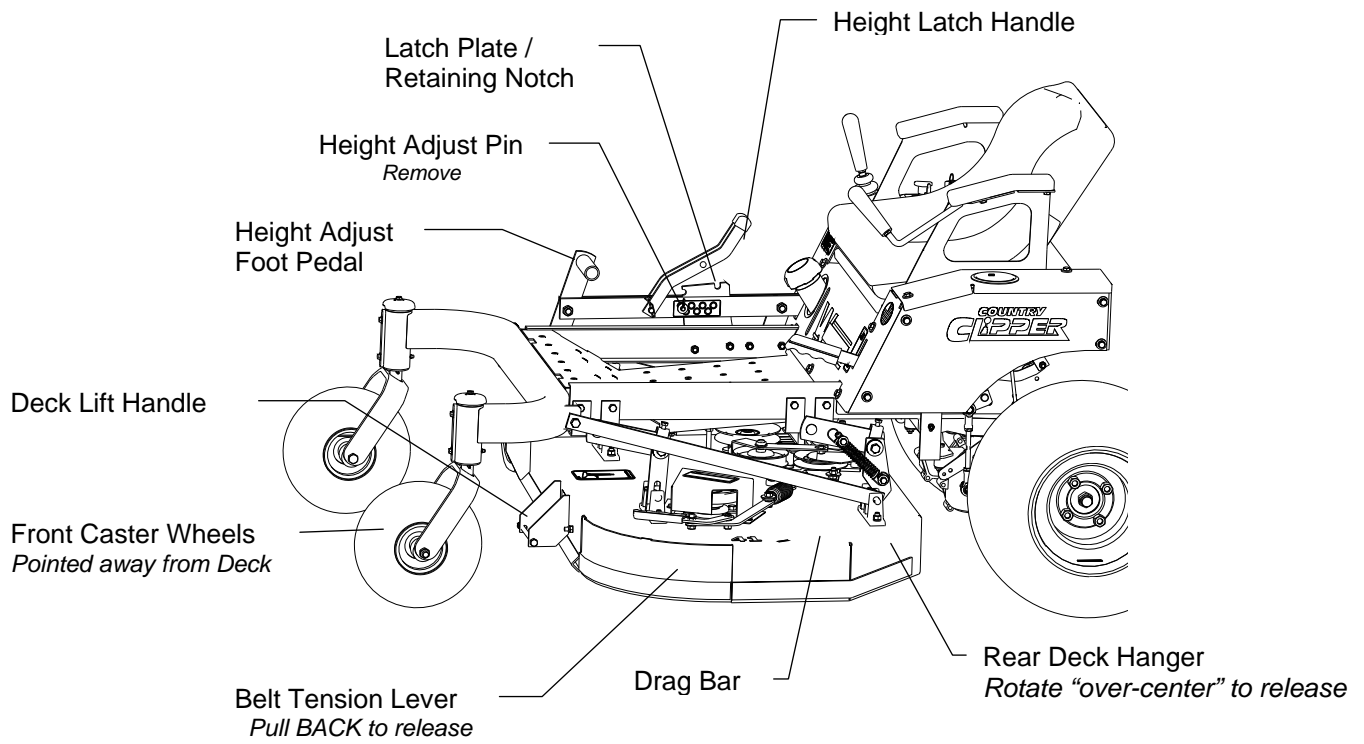

MOWER SHOWN IN SERVICING POSITION.

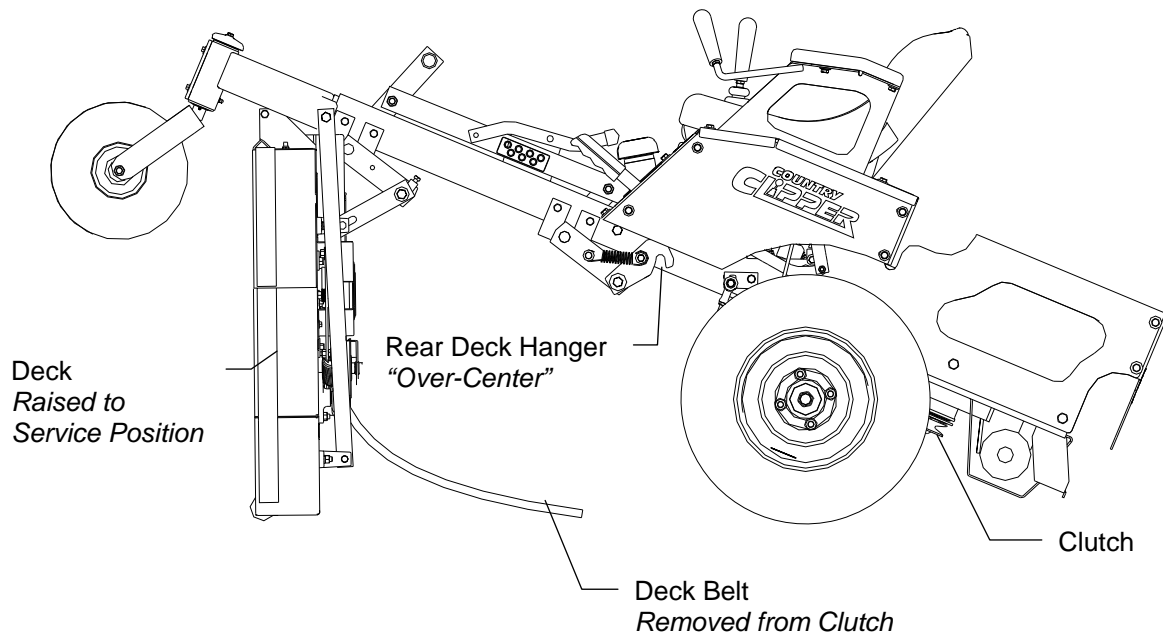

TROUBLE SHOOTING CHECK LIST

1. ENGINE WON'T TURN OVER:
 - Mower blades engaged ----- disengage blades
 - Drive not in neutral ----- move Joystick Control Lever to neutral position
 - Blown fuse ----- replace fuse
 - Dead battery ----- charge or replace
 - Solenoid ----- consult dealer
 - Ignition switch ----- consult dealer
 - Starter ----- consult dealer

2. ENGINE WILL TURN OVER BUT WON'T START:
 - No gas ----- refuel
 - clean or replace fuel filters
 - Over or under choked ----- adjust choke
 - Spark plug not firing ----- check spark plug
 - condition and reset gap*
 - Carburetor maladjustment ----- reset carburetor adjustment*
 - Ignition switch ----- consult dealer

3. HARD TO START ENGINE:
 - Fuel line clogged ----- clean fuel line and check fuel filter
 - Faulty fuel pump ----- consult dealer
 - Spark plug wire loose or grounded ----- check spark plug wires
 - Spark plug(s) faulty or improperly gapped ----- check spark plug
 - condition and reset gap*
 - Electronic ignition defective ----- consult dealer
 - Dirty or maladjusted carburetor ----- readjust carburetor*
 - consult dealer for carburetor service

4. ENGINE STARTS BUT CUTS OUT:
 - Water in gasoline ----- drain old gasoline and replace with new gasoline
 - clean carburetor bowl
 - Clogged fuel line ----- check fuel filter
 - clean fuel line
 - Faulty fuel pump ----- consult dealer
 - Maladjusted carburetor ----- readjust carburetor*
 - Engine dies when Joystick Control Lever is move from "neutral"--- park brake set
 - release brake

5. ENGINE KNOCKS:
 - Low oil level ----- check and add oil
 - Ignition timing off ----- consult dealer
 - Fuel octane too low ----- drain and replace with
 - higher octane gasoline
 - Over heated engine ----- shut off engine and allow to cool

* See engine manual for engine adjustments.

6. ENGINE SOMETIMES SKIPS AT HIGHER SPEEDS:

BELT ROUTINGS

Hydrostatic Transmission Drive Belt (Viewed from ground looking up)

Right Hand Hydrostatic
Transmission Pulley

Left Hand Hydrostatic
Transmission Pulley

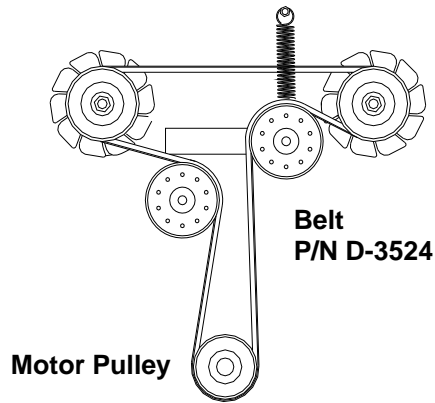

41" DECK BELT P/N D--3796

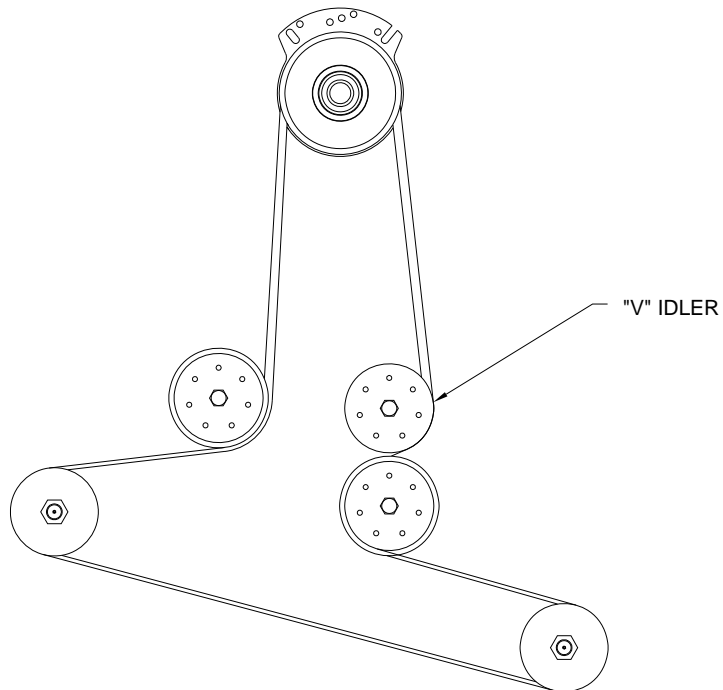

WIRING SCHEMATIC

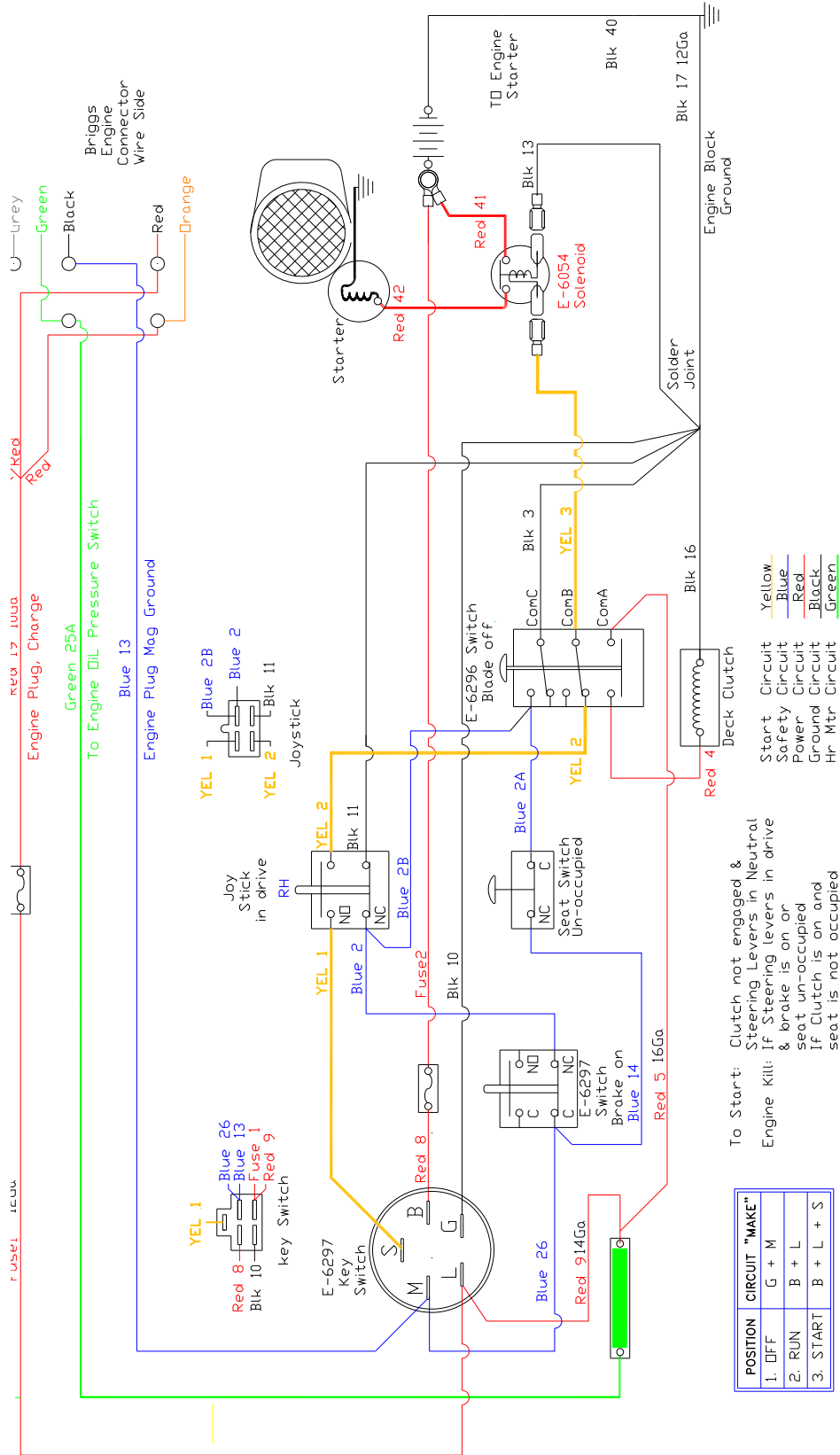

Safety Instructions & Operators Manual

COUNTRY CLIPPER®

Zero Turn Radius Mower

W **WRANGLER**

SR-125



WARNING



The engine exhaust from this product contains chemicals known to the State of California to cause cancer, birth defects, or other reproductive harm.

Country Clipper Division
Shivers Manufacturing Inc.
613 W. English St.
Corydon, IA 50060-0467
Ph. 641-872-2544
Fax. 641-872-1593